

CONGRATULATIONS!

This guide will show you how to connect all of the different parts of your Spectrum 370AV System. Simply perform the following steps (on both sides) to build your new system.

For more detailed connection information, and to learn how to assemble the rack and operate all of the system's components, please read the manuals that come with the rack and the components.

STEP 1 - Stacking The Components In The Rack

To make sure that they're properly ventilated and stable, stack the components according to the diagram on the right. If you're using a turntable, place it on top of the rack.

IMPORTANT: Do not plug the receiver's power cord into an AC outlet until you have properly made all of the connections listed in steps 3 through 7.

SPECTRUM 370AV RACK

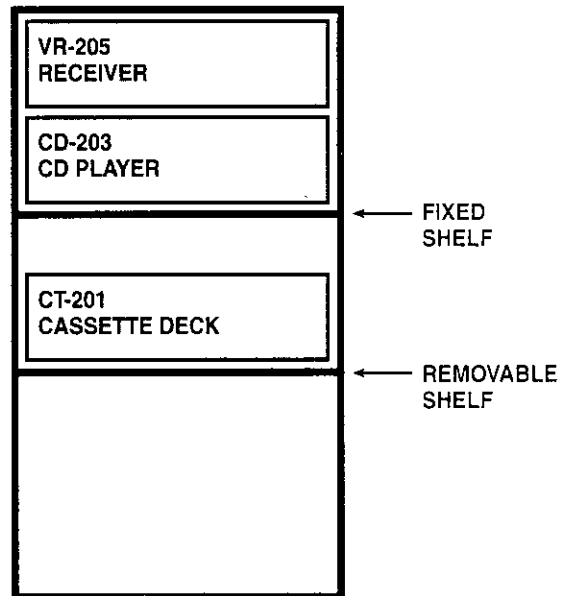

STEP 2 - Placing The Speakers

Place the speakers as shown in the diagram on the right. While you're setting the speakers up, keep these points in mind:

- Since the left, right, and center speakers are magnetically-shielded, you can place them near the TV without picture discoloration. The center speaker can be placed right on top of the TV.
- You can hang the surround speakers on the wall using heavy-duty picture hangers.
- Placing the left and right speakers next to a wall produces more deep bass output than placing them away from a wall. Placing the speakers in corners produces the deepest bass output overall, but may cause the sound to become "muddy" or "heavy."

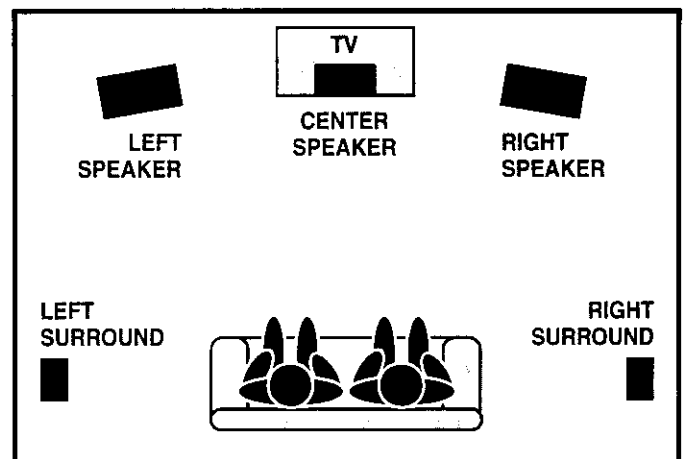

STEP QUICK-CONNECT GUIDE

STEP 3 - Connecting The Speakers

Connect the speakers as shown in the diagram on the right, using the wires supplied with the speakers. To make it easier, we've removed the insulation from the ends of the wires.

- Be sure to connect the (+) terminals on the receiver to the (+) terminals on the speakers, and the (-) terminals on the receiver to the (-) terminals on the speakers. Connecting (+) to (-) can cause poor sound quality.
- Never allow the (+) and (-) speaker wires to touch each other. Touching wires can cause a short circuit, which could damage the receiver.

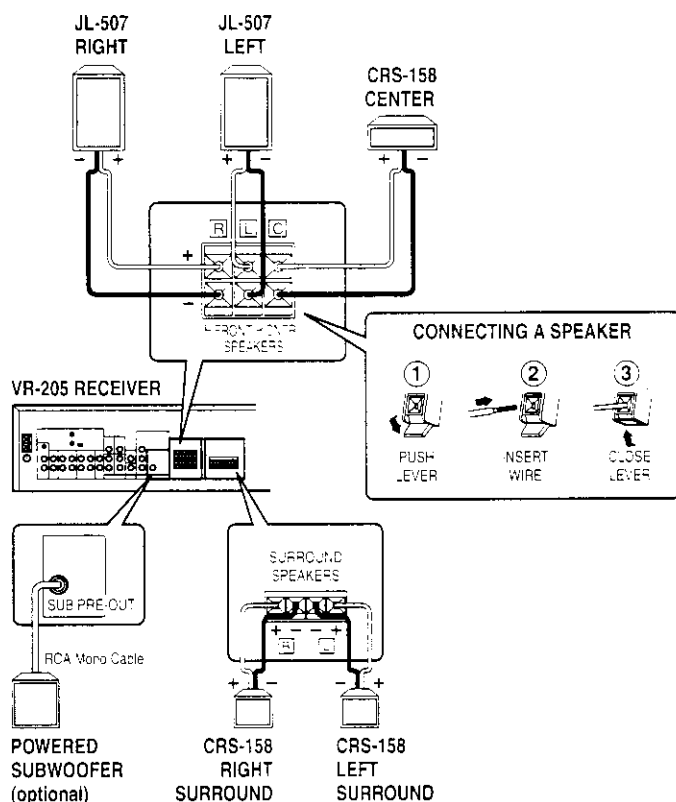

STEP 4 - Connecting The Audio Components

Connect the components that came with the system as shown in the diagram on the right. Use the cables supplied with each component. You can connect any turntable that has a magnetic phono cartridge.

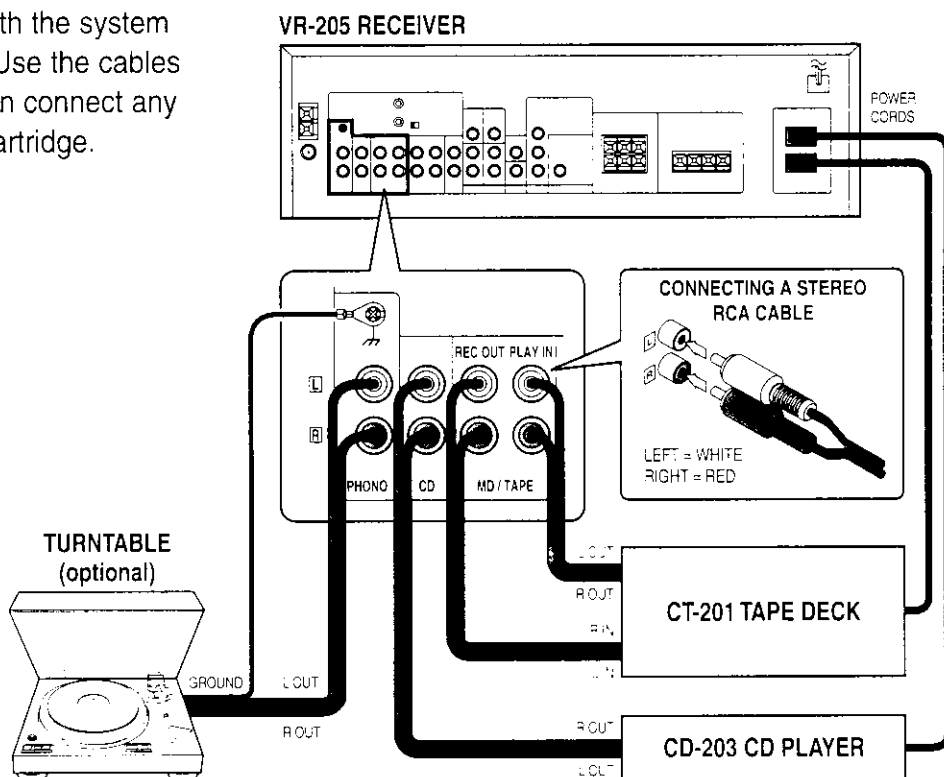

STEP 5 - Connecting the System Control Cable

Connect the System Control cable between the receiver and CD player as shown in the diagram on the right. Be sure to push the plugs all the way in.

NOTE: Make sure that the SL16/XS8 switch is in the SL16 position.

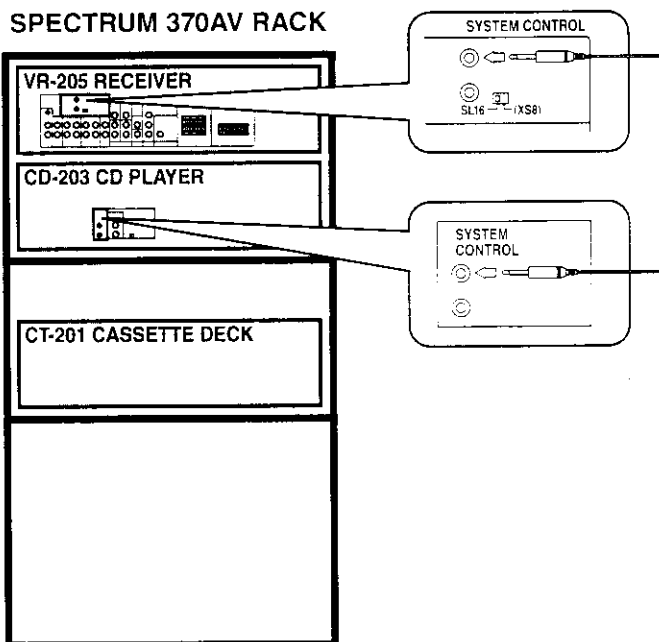

STEP 6 - Connecting Video Components

If you use an optional VCR, laser disc player, or DVD player's 2-channel analog connections with your Spectrum 370 System, connect them as shown in the diagram on the right.

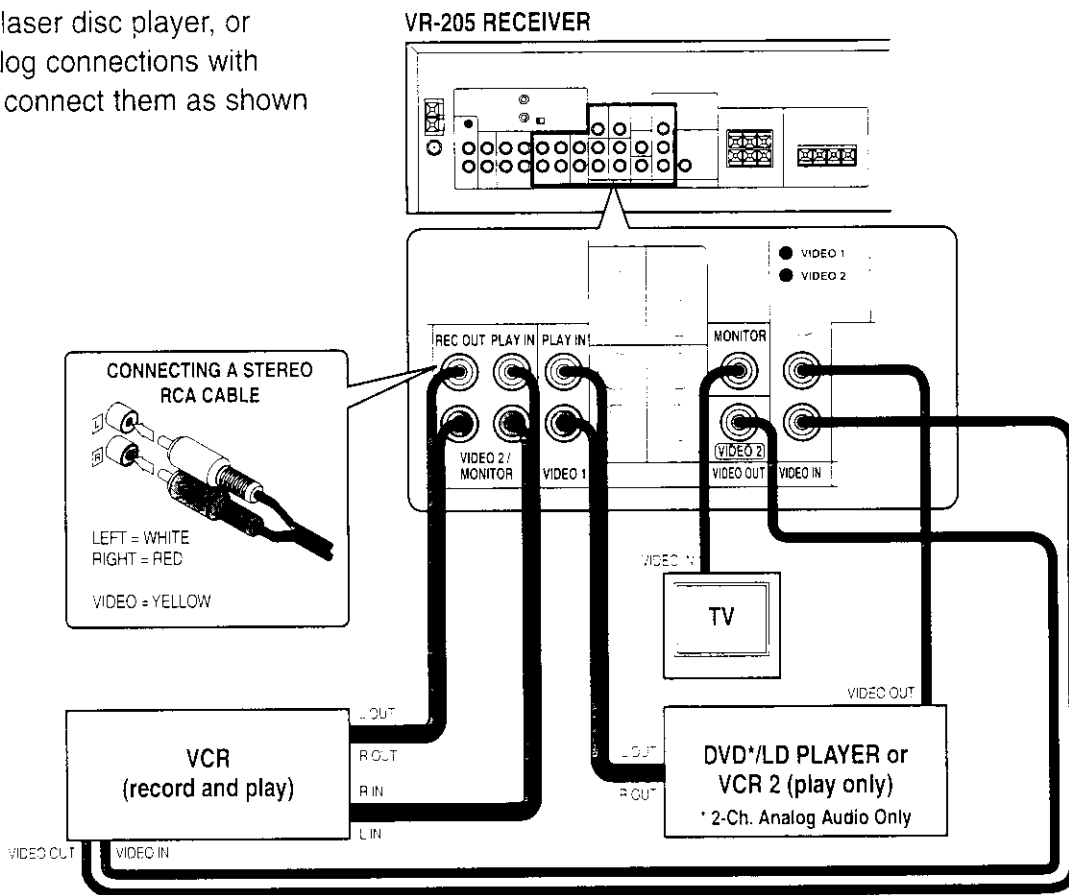

STEM QUICK-CONNECT GUIDE

STEP 7 – Connecting a DVD Player

Connect a DVD player with 6-channel analog outputs to the receiver as shown in the diagram on the right.

If the DVD player does not have a 6-channel analog output, connect its 2-channel analog output to the video 2 input, as shown in the diagram in *STEP 6 – Connecting Video Components*.

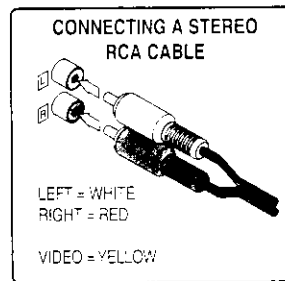

VR-205 RECEIVER

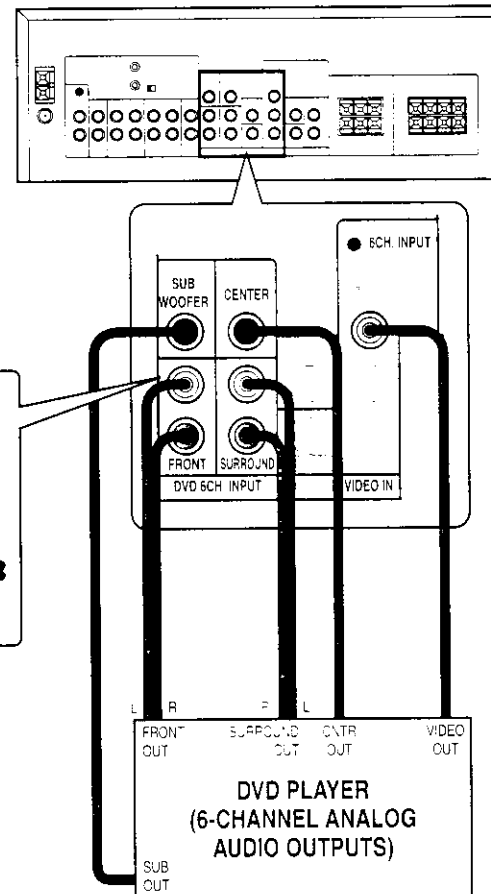

QUESTIONS ABOUT YOUR NEW SYSTEM?

If you have any questions about your new system, please contact our Stage 3 Customer Service Department on any business day at:

- (310) 639-5300 from 8:30 A.M. to 5:00 P.M., Pacific Time

Or visit our website anytime at:

- www.kenwoodusa.com